

No.583 Capilograph Model F-1 / F-2

Capillary Rheometer (Single & twin bore barrel)



■ APPLICATION

Toyoseiki **Capillary Rheometers “Capilograph”** measures melt viscosity of polymers by detecting the shear rate and shear stress of melt polymer when it flows out of the capillary die. Die swell and melt strength (melt tension) can also be measured by optional attachments.

The twin bore barrel model (F-2) allows easy Bagley & Weissenberg-Rabinowitsch correction (for determination of true viscosity) or elongational viscosity calculation in a single test run.

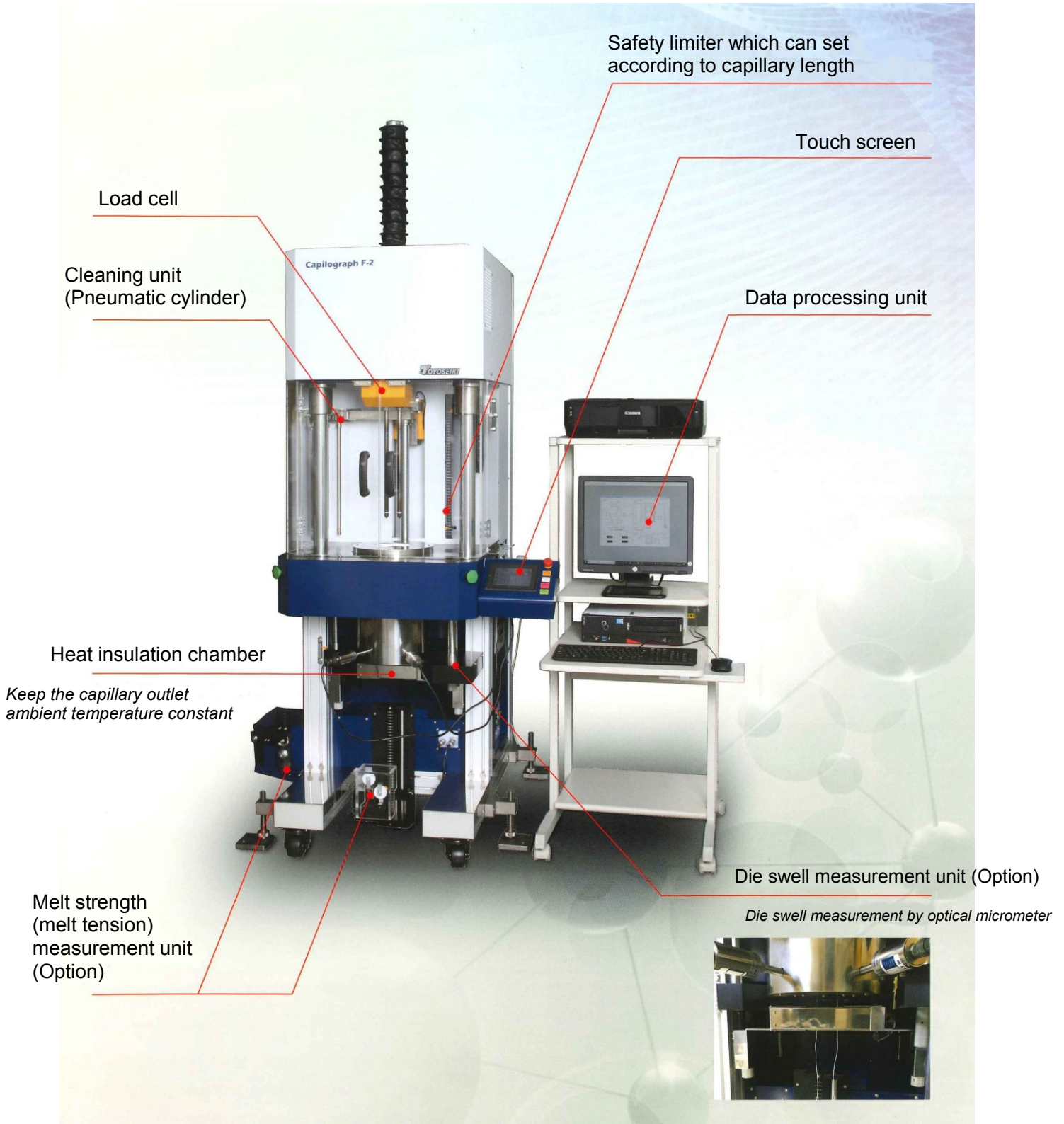

■ MELT STRENGTH (MELT TENSION) MEASUREMENT (OPTIONAL)

Drawing speed can be selected from 200m/min., 400m/min. and 500/min.

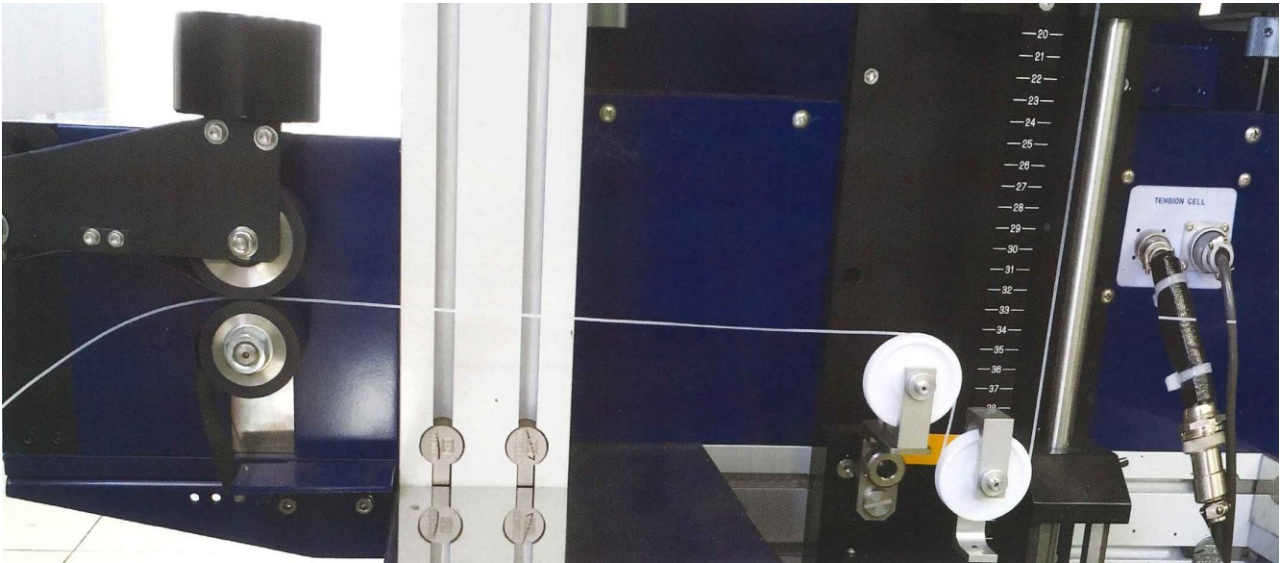

■ DIE SWELL MEASUREMENT (OPTIONAL)

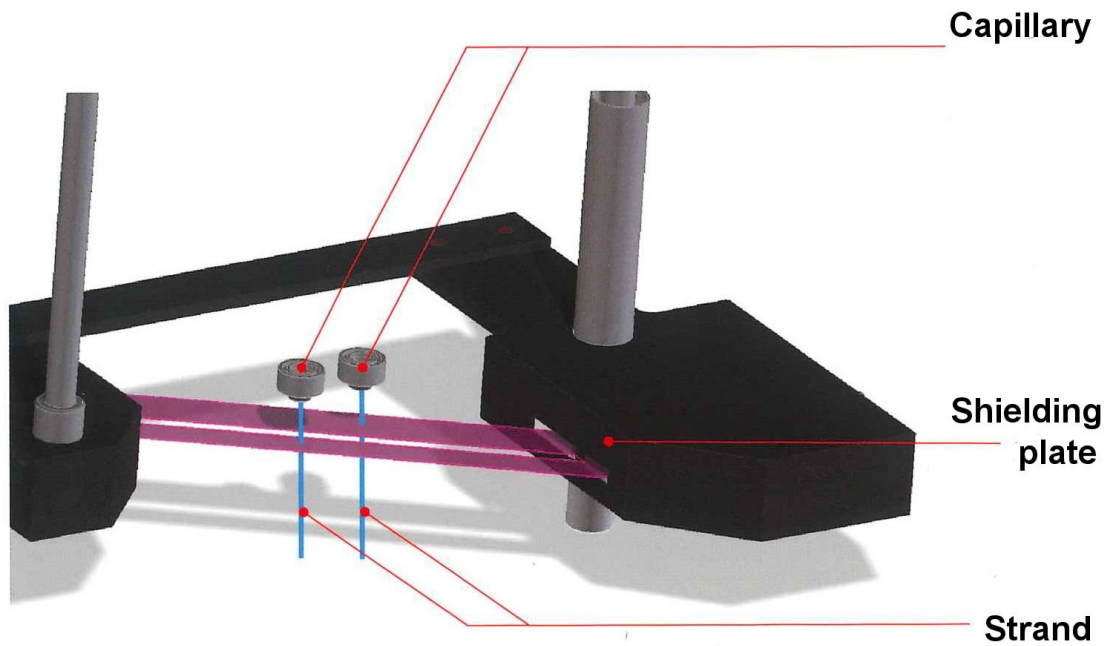

Die swell measurement (Twin bore barrel)

EXAMPLES OF MEASUREMENT



[Capillary Flow Test Data]

測定日: 2016/04/19
 サンプル名: HDPE
 測定者: TEST
 測定条件: L:10.00[mm] D:1.000[mm] B:9.55[mm] T:200.0[mm]

V [mm/min]	Load [kN]	ShearRate[1/s]	ShearStress[Pa]	Viscosity[Pa·s]	Pressure[Pa]	Die Swell
5.00	539.904	6.080E+01	1.884E+05	3.099E+03	7.537E+06	1.197
10.00	888.288	1.216E+02	2.402E+05	1.975E+03	9.609E+06	1.206
20.00	866.784	2.432E+02	3.025E+05	1.244E+03	1.210E+07	1.197
50.00	984.032	6.080E+02	3.434E+05	5.649E+02	1.374E+07	1.178
100.00	1257.024	1.216E+03	4.387E+05	3.608E+02	1.755E+07	1.227
200.00	1552.064	2.432E+03	5.417E+05	2.227E+02	2.167E+07	1.249
500.00	1984.512	6.080E+03	6.926E+05	1.139E+02	2.770E+07	1.273
1000.00	2343.660	1.216E+04	8.180E+05	6.727E+01	3.272E+07	1.306
1.00	312.166	1.216E+01	1.090E+05	8.960E+03	4.358E+06	1.189
2.00	395.187	2.432E+01	1.379E+05	5.671E+03	5.517E+06	1.184

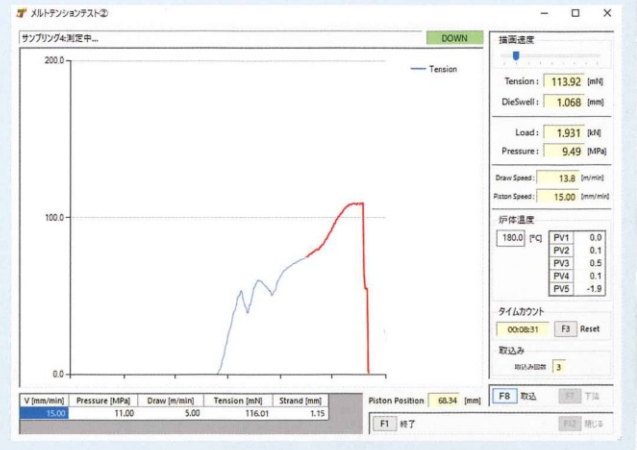
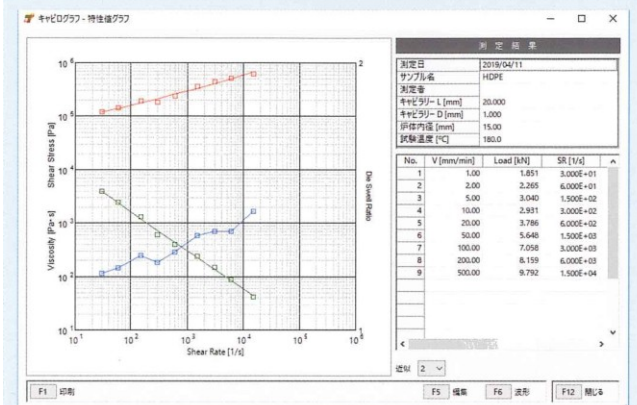
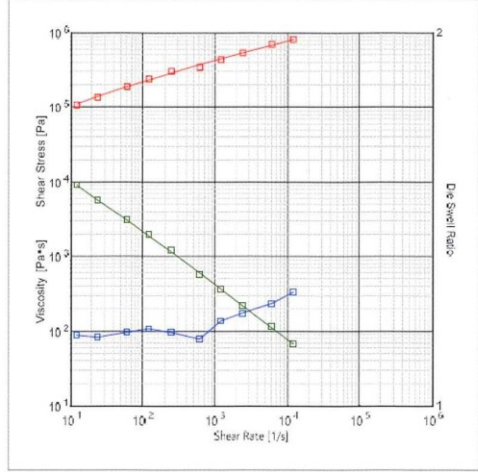

***** Melt Tension (1) Test Data *****

測定日: 2018/04/20
 サンプル名: Test
 測定者: TEST
 測定条件: L:8.02[mm] D:2.095[mm] B:9.55[mm] T:200.0[mm]

V[mm/min]	Draw[m/min]	Tmax[mN]	Tmin[mN]	Tave[mN]	Strand[mm]	DR	WP[s]	A[mN]
10.00	10.0	0.06	0.06	0.06	1.005	48.124	1.07	1.93
10.00	10.0	0.06	0.05	0.05	1.003	48.124	0.69	0.93
10.00	10.0	0.06	0.05	0.05	1.008	48.124	0.99	1.71
10.00	10.0	0.05	0.05	0.05	1.009	48.124	1.16	1.82
10.00	10.0	0.06	0.05	0.05	1.063	48.124	1.03	1.67

***** Melt Tension (2) Test Data *****

測定日: 2018/04/20
 サンプル名: Test
 測定者: TEST
 測定条件: L:10.00[mm] D:1.000[mm] B:9.55[mm] T:200.0[mm]

V[mm/min]	Pressure[MPa]	Draw[m/min]	Tension[mN]	Strand[mN]	Acc.[m/s^2]	Draft Ratio
10.00	1020.6	53.50	0.06	0.991	0.055556	58.661
10.00	1020.6	42.80	0.06	0.992	0.055556	46.929
10.00	1020.6	54.90	0.06	0.987	0.055556	60.196
10.00	1020.6	31.10	0.05	0.803	0.055556	34.100

EXAMPLES OF DATA PROCESSING

[Capillary Flow Test Data]

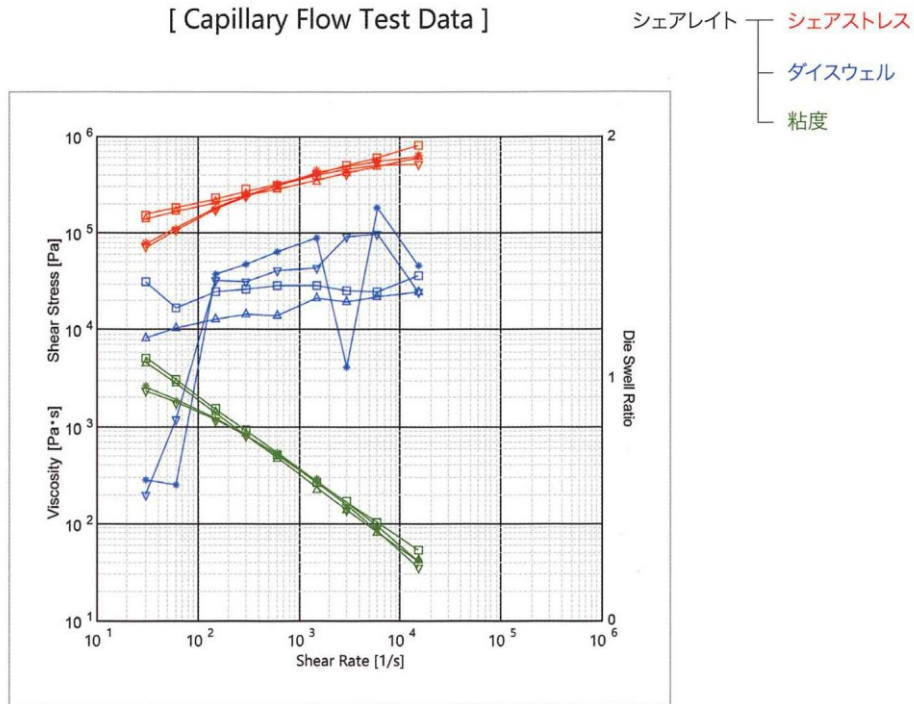

[Capillary Flow Test Data]

測定日 2018/02/26
 サンプル名 * LDPE_φ15mm_圧力センサー
 測定者
 測定条件 L:10.00[mm] D:1.000[mm] B:15.00[mm] T:190.0[mm]

V [mm/min]	Load [kN]	ShearRate[1/s]	ShearStress[Pa]	Viscosity[Pa·s]	Pressure[Pa]	Die Swell
1.00	541.992	3.000E+01	7.935E+04	2.645E+03	3.174E+06	0.579
2.00	765.625	6.000E+01	1.108E+05	1.847E+03	4.434E+06	0.557
5.00	1263.672	1.500E+02	1.787E+05	1.191E+03	7.148E+06	1.428
10.00	1756.836	3.000E+02	2.462E+05	8.207E+02	9.849E+06	1.472
20.00	2333.008	6.000E+02	3.251E+05	5.418E+02	1.300E+07	1.525
50.00	3193.359	1.500E+03	4.425E+05	2.950E+02	1.770E+07	1.582
100.00	3210.938	3.000E+03	4.395E+05	1.465E+02	1.758E+07	1.048
200.00	4130.859	6.000E+03	5.618E+05	9.364E+01	2.247E+07	1.705
500.00	4714.355	1.500E+04	6.302E+05	4.201E+01	2.521E+07	1.464

測定日 2018/02/26
 サンプル名 ▽ LDPE_φ15mm_圧力センサー
 測定者
 測定条件 L:20.00[mm] D:1.000[mm] B:15.00[mm] T:190.0[mm]

V [mm/min]	Load [kN]	ShearRate[1/s]	ShearStress[Pa]	Viscosity[Pa·s]	Pressure[Pa]	Die Swell
1.00	997.070	3.000E+01	7.141E+04	2.380E+03	5.713E+06	0.516
2.00	1500.000	6.000E+01	1.060E+05	1.767E+03	8.484E+06	0.830
5.00	2477.539	1.500E+02	1.741E+05	1.161E+03	1.393E+07	1.403
10.00	3449.219	3.000E+02	2.420E+05	8.067E+02	1.936E+07	1.399
20.00	4580.078	6.000E+02	3.214E+05	5.356E+02	2.571E+07	1.448
50.00	5808.105	1.500E+03	4.076E+05	2.717E+02	3.260E+07	1.456
100.00	5961.914	3.000E+03	4.146E+05	1.382E+02	3.317E+07	1.586
200.00	7609.863	6.000E+03	5.267E+05	8.779E+01	4.214E+07	1.594
500.00	7641.602	1.500E+04	5.235E+05	3.490E+01	4.188E+07	1.357

OPTIONAL SOFTWARE 1

Bagley correction (Capillary length correction coefficient calculation) & Weissenberg-Rabinowitsch correction (Optional software)

Note: Two or more capillary dies of same diameter but different lengths are required.

● Bagley correction

Shear stress with Bagley correction coefficient EC

$$\tau_c = \frac{Pr}{2(L+Ecr)} \text{ (Pa)}$$

● Weissenberg-Rabinowitsch correction

True Shear Rate

$$\dot{\gamma}_c = \frac{\dot{\gamma}_a}{4} \left(3 + \frac{d \log \dot{\gamma}_a}{d \log \tau_c} \right) \text{ (sec}^{-1}\text{)}$$

True Viscosity

$$\eta_c = \frac{\tau_c}{\dot{\gamma}_c} \text{ (Pa} \cdot \text{s)}$$

P: Barrel's internal pressure (Pa)

F: Extrusion load (N)

R: Radius of barrel (m)

r: Radius of capillary (m)

L: Length of capillary (m)

Q: Flow rate (m³/min)

V: Extrusion volume (m³/min)

v: Extrusion rate (m/min)

t: Time (60) (sec)

Ec: Capillary length correction coefficient

$V = \pi R^2 v$ (m³/min)

$Q = V/t = V/60$ (m³/s)

$P = F / \pi R^2$ (Pa)

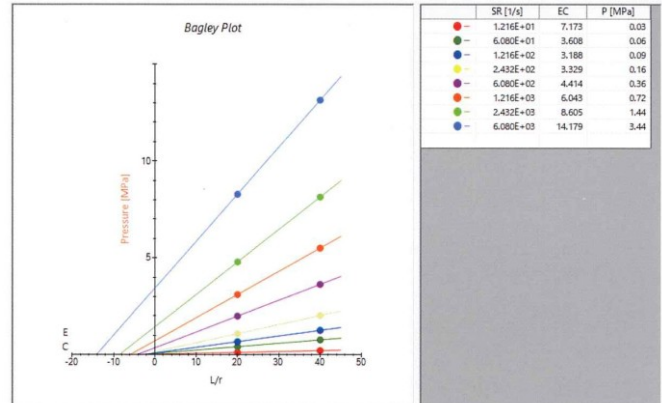

Bagley correction is the value at the point of intersection of the X axis with the extension of the curve plotted with regard to each Shear rate by taking pressure P of polymer along the Y axis and L/r of capillary along the X axis.

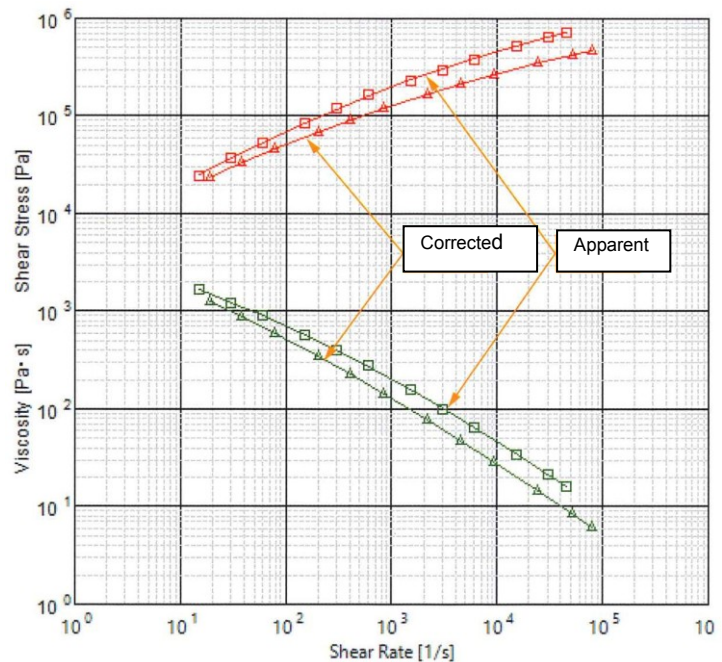

Comparison of apparent curves with capillary L=5mm, D=1mm and L/D=5 and curves after Weissenberg-Rabinowitsch correction and capillary length correction.

OPTIONAL SOFTWARE 2

Automatic data capture

- Stabilization condition setting example

自動取込設定
Stroke Total = 175.0/180.0

No.	V [mm/min]	SR1 [1/s]	Limit [mm]	Balance Item	
				[kN]	[s]
1	1.00	1.216E+01	5	0.1	330
2	2.00	2.432E+01	5	0.1	30
3	5.00	6.080E+01	5	0.1	20
4	10.00	1.216E+02	10	0.2	20
5	20.00	2.432E+02	10	0.2	15
6	50.00	6.080E+02	20	0.2	10
7	100.00	1.216E+03	30	0.5	3
8	200.00	2.432E+03	40	0.5	3
9	500.00	6.080E+03	50	0.8	2

予熱 Time 360 [s]
位置 ○ 250mm ● 200mm

緩和オプション
 取込時荷重の 90.0 [%] 降下で再開
 取込後 10.0 [s] 経過で再開

This software automatically judges stabilization of extrusion load, automatically samples data and performs data processing.

By setting sample's extrusion test speed and stability conditions (data sampling interval, permissible load fluctuation range, stability continuation time) beforehand, tests are automatically conducted.

OPTIONAL SOFTWARE 3

Elongational viscosity calculation using Congswell's analysis

The reduction flow at contracted flow place in capillary inflow region gives rise to elongational deformation of resin because of increase in flow speed. This software calculates elongational viscosity from the loss of pressure due to elongational flow based on the theory of cogswell. For using this software, shear viscosity data measured by two capillaries of sample diameter, length of $L \doteq 0$ and $L > 0$ is necessary.

- Elongational Stress σ^E

$$\sigma^E = \frac{3}{8} (n+1) P_0 \quad (\text{Pa})$$

- Elongational Viscosity λ

$$\lambda = \frac{9 (n+1)^2 P_0^2}{32 \eta \dot{\gamma}^2} \quad (\text{Pa} \cdot \text{s})$$

- Elongational Speed ε

$$\varepsilon = \frac{\sigma^E}{\lambda} \quad (\text{sec}^{-1})$$

n: Non-Newtonian index

Po: Inflow pressure at $L \doteq 0$

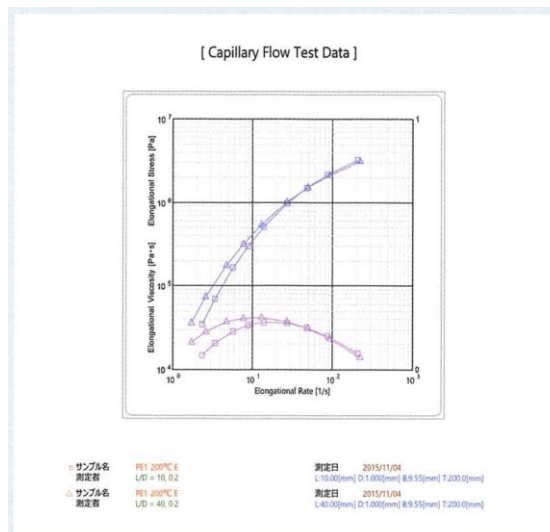

■ SPECIFICATIONS

Model		F-1	F-2
Furnace	Temperature range	60 to 400°C (500°C: Optional)	
	Temperature accuracy	±1°C (Less than 300°C) Within ±2°C (300°C or more) <i>Note: Within effective length</i>	
	Temperature resolution	0.1°C	
	Barrel type	Single bore	Twin bore
	Bore diameter	Ø9.55mm or Ø15mm	Ø15mm
	Barrel length	Length: 350mm Effective length: 250mm	
Drive system	Piston speed	0.1 to 1500mm/min.	
	Speed resolution	0.01mm/min.	
	Motor capacity	1.5kW (AC servo motor)	
Load measurement	Max. force range (Load cell capacity)	25kN (Bore dia. Ø9.55mm) 50kN (Bore dia. Ø15mm)	25kN (Bore dia. Ø15mm)
	Load display resolution	1N (0.001kN)	
Pressure measurement* (Optional)	Max pressure	200MPa	
	Resolution	0.01MPa	
	Max. temperature	400°C	
Die swell (Optional)	Measurement position	Nozzle bottom, 0 to 35mm	
	Measurement range	0.5 to 9.999mm	
	Measurement accuracy	±5µm	
	Measurement method	LED/CCD optical micrometer with a high-intensity Green LED	
Melt strength (Melt tension) (Optional)	Measurement position	100 to 520mm	
	Max. load	2N	
	Display resolution	0.1mN (0.0001N)	
	Drawing speed	Select one from below ■ 0.1 to 200m/min. ■ 0.1 to 400m/min. ■ 0.1 to 500m/min. Equipped with variable speed & automatic acceleration function	
Utilities, dimensions etc.	Power requirement	Three-phase, AC200V, 50Hz or 60Hz, 5.2kVA (For main unit) Single-phase, AC100V, 50Hz or 60Hz, 0.3kVA (For PC)	
	Compressed air requirement	0.4 to 0.5MPa	
	Dimensions	W1060 x D1100 x H1950 to 2360mm (Main unit)	
	Weight	Approx. 650kg (Main unit)	
	Related standards	ISO 11443 (JIS K 7199)... <i>Plastics-Determination of the fluidity of plastics using capillary and slit-die rheometers.</i> ASTM D3835... <i>Standard Test Method for Determination of Properties of Polymeric Materials by Means of a Capillary Rheometer.</i>	

*Pressure measurement (Optional) can be selected only with Ø15mm bore barrel.

■ OPTIONS

1. Capillary dies

Models Entry angle: 180° (Flat)	Models Entry angle: 90°	Diameter (mm)	Length (mm)	L/D	Material
AF	A	2.095	8.0	3.8	Tungsten carbide
BF	B	0.5	5.5	5	
CF	C	0.5	5.0	10	
DF	D	1.0	5.0	5	
EF* ¹	E	1.0	10.0	10	
FF	F	1.0	20.0	20	
GF	G	1.0	40.0	40	
HF	H	1.27	50.8	40	
IF	I	2.0	10.0	5	
JF	J	2.0	20.0	10	
KF	K	1.53	25.4	16.6	

*¹ One piece of model EF capillary die is provided as standard.

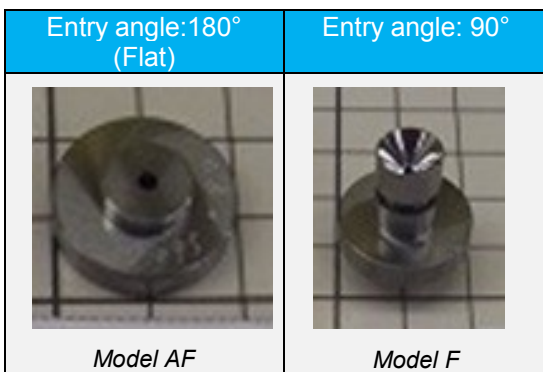

2. Pressure transducer

- Max pressure: 200MPa
- Resolution: 0.01MPa
- Max. temperature: 400°C

*Note: Available for Ø15mm barrel only.
(Not available for Ø9.55mm barrel)*

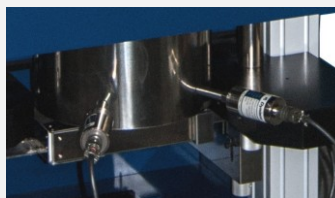

3. Die swell measurement unit

- Measurement method: LED/CCD optical micrometer with a high-intensity Green LED
- Accuracy: $\pm 5\mu\text{m}$
- Measurement range: 0.5 to 9.999mm
- Measurement position: Nozzle bottom, 0 to 35mm

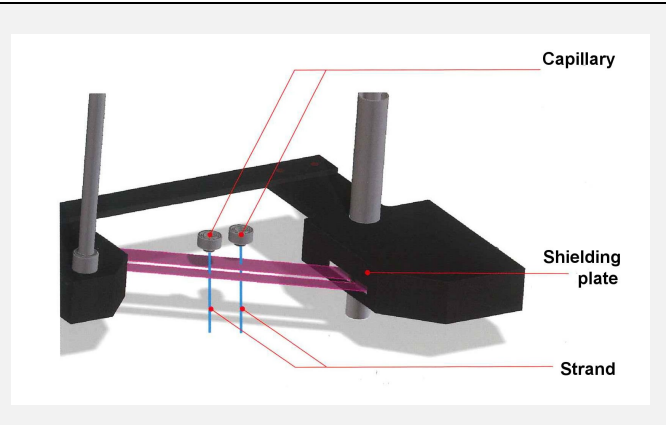

4. Melt strength (melt tension) measurement unit

- Speed range: Select one from below
 - 1) 0.1 to 200mm/min.
 - 2) 0.1 to 400mm/min.
 - 3) 0.1 to 500mm/min.

- Load cell: 2N
- Resolution: 0.0001N (0.1mN)

Equipped with variable speed & automatic acceleration function

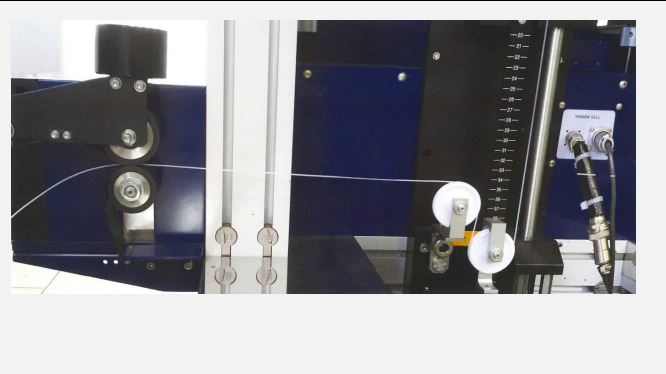

■ CALUCLATION FORMULA

Apparent Shear stress $\tau_a = \frac{Pr}{2L}$ (Pa)

Apparent Shear rate $\dot{\gamma}_a = \frac{4Q}{\pi r^3}$ (sec⁻¹)

Apparent Viscosity $\eta_a = \frac{\tau_a}{\dot{\gamma}_a}$ (Pa·s)

$$P = \frac{F}{\pi R^2} \text{ (Pa)}$$

P	Barrel internal pressure	(Pa)
F	Extrusion load	(N)
R	Barrel radius	(m)
r	Capillary radius	(m)
L	Capillary length	(m)
Q	Flow rate	(m ³ /s)

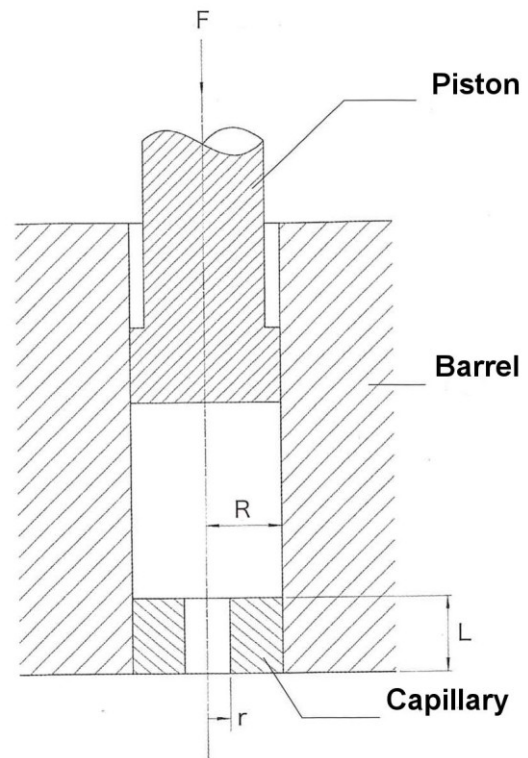



■ STANDARD ACCESSORIES & OPTIONS

● Standard ○ Option

	Name	Model (P/N)	F-1/F-2	Photo
1	Capillary mounting nut	(2160267)	●	
2	Handle for furnace	----	●	
3	Handle for capillary mounting nut	----	●	
4	Funnel	----	●	
5	Sample filling rod	----	●	
6	Cylinder cleaning rod	(2100335)	●	
7	Capillary push out rod	----	●	
8	Piston (Standard type, with O-ring)		●	
9	Piston (High temperature type, without O-ring)		○	
10	Capillary die (Standard type) ■ Length: 10.0mm ■ Diameter: 1.0mm ■ L/D: 10mm ■ Entry angle: 180° (Flat)	EF (2110130)	●	
11	Capillary die ■ Length: 10.0mm ■ Diameter: 1.0mm ■ L/D: 10mm ■ Entry angle: 90°	E (2110117)	○	
12	Capillary die ■ Length: 8.0mm ■ Diameter: 2.095mm ■ L/D: 3.8mm ■ Entry angle: 90°	A (2110122)	○	
13	Capillary die ■ Length: 8.0mm ■ Diameter: 2.095mm ■ L/D: 3.8mm ■ Entry angle: 180° (Flat)	AF (2110126)	○	
14	Capillary die ■ Length: 2.5mm ■ Diameter: 0.5mm ■ L/D: 5mm ■ Entry angle: 90°	B	○	
15	Capillary die ■ Length: 2.5mm ■ Diameter: 0.5mm ■ L/D: 5mm ■ Entry angle: 180° (Flat)	BF (2110127)	○	

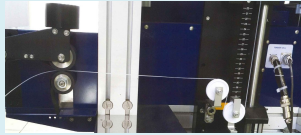
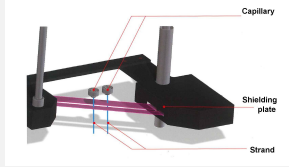
16	<p>Capillary die</p> <ul style="list-style-type: none"> ■ Length: 5.0mm ■ Diameter: 0.5mm ■ L/D: 10mm ■ Entry angle: 90° 	C	○	
17	<p>Capillary die</p> <ul style="list-style-type: none"> ■ Length: 5.0mm ■ Diameter: 0.5mm ■ L/D: 10mm ■ Entry angle: 180° 	CF (2110128)	○	
18	<p>Capillary die</p> <ul style="list-style-type: none"> ■ Length: 5.0mm ■ Diameter: 1.0mm ■ L/D: 5mm ■ Entry angle: 90° 	D (2110125)	○	
19	<p>Capillary die</p> <ul style="list-style-type: none"> ■ Length: 5.0mm ■ Diameter: 1.0mm ■ L/D: 5mm ■ Entry angle: 180° (Flat) 	DF (2110129)	○	
20	<p>Capillary die</p> <ul style="list-style-type: none"> ■ Length: 20.0mm ■ Diameter: 1.0mm ■ L/D: 20mm ■ Entry angle: 90° 	F (2110118)	○	
21	<p>Capillary die</p> <ul style="list-style-type: none"> ■ Length: 20.0mm ■ Diameter: 1.0mm ■ L/D: 20mm ■ Entry angle: 180° (Flat) 	FF (2110131)	○	
22	<p>Capillary die</p> <ul style="list-style-type: none"> ■ Length: 40.0mm ■ Diameter: 1.0mm ■ L/D: 40mm ■ Entry angle: 90° 	G (2110119)	○	
23	<p>Capillary die</p> <ul style="list-style-type: none"> ■ Length: 40.0mm ■ Diameter: 1.0mm ■ L/D: 40mm ■ Entry angle: 180° (Flat) 	GF (2110132)	○	
24	<p>Capillary die</p> <ul style="list-style-type: none"> ■ Length: 10.0mm ■ Diameter: 2.0mm ■ L/D: 5mm ■ Entry angle: 90° 	I (2110120)	○	
25	<p>Capillary die</p> <ul style="list-style-type: none"> ■ Length: 10.0mm ■ Diameter: 2.0mm ■ L/D: 5mm ■ Entry angle: 180° (Flat) 	IF (2110133)	○	
26	<p>Capillary die</p> <ul style="list-style-type: none"> ■ Length: 20.0mm ■ Diameter: 2.0mm ■ L/D: 10mm ■ Entry angle: 90° 	J (2110121)	○	
27	<p>Capillary die</p> <ul style="list-style-type: none"> ■ Length: 20.0mm ■ Diameter: 2.0mm ■ L/D: 10mm ■ Entry angle: 180° (Flat) 	JF (2110134)	○	

28	Capillary die for elongational viscosity calculation (Zero-length type) ■ Length: \approx 0mm ■ Diameter: 1.0mm	-----	○	
29	Capillary cleaning rod, for D=1mm	(2101011)	●	
30	Capillary cleaning rod, for D=1mm, L=40mm or greater	(1300134)	○	
31	Capillary cleaning rod, for D=0.5mm	(2101010)	○	
32	Capillary cleaning rod, for D=2mm	(2101012)	○	
33	O-ring for standard piston (Teflon packing)	(4202936)	●	
34	O-ring insert rod	(2100336)	●	
35	Data processing unit (PC, Printer, Capilograph software)	-----	●	
36	Melt strength (melt tension) measurement unit	-----	○	
37	Die swell measurement unit	-----	○	
38	Bagley correction (Capillary length correction coefficient calculation) & Weissenberg-Rabinowitsch correction (Optional software)	-----	○	
39	Automatic data capture software (Optional software)	-----	○	
40	Elongational viscosity calculation (Optional software)	-----	○	
41	Pressure transducer	-----	○	

■ No.633 P-V-T Test System, model A2



The **P-V-T Test System** measures relationship data in the form of Pressure-Volume (Specific)-Temperature of melting polymers required at the time of actual polymer processing just with a small quantity of sample.

■ Thermal Conductivity Tester, model LS-1



The **Thermal Conductivity Tester** measures thermal conductivity of plastic materials during the transition from melted state to solid state. The tester is also capable of measuring the conductivity during the change of state from solid to melted state.

Specifications are subject to change without notice.



TOYO SEIKI SEISAKU-SHO, LTD.

5-15-4, Takinogawa, Kita-ku, Tokyo 114-8557, Japan

Tel:+81-3-3916-8183 Fax:+81-3-3916-8173

www.toyoseiki.co.jp

20191204 MN